

# SABA

## 355 WP Preßstoffgehäuse

## 355 WH Holzgehäuse

für Wechselstrom

# SABA

## 356 GW Preßstoffgehäuse

für Gleich- und Wechselstrom

355  
356

Sechskreis-Zweiwellenbereich-Vollsuper mit 4 Röhren



Sender-  
Einstellknopf

Wellenschalter

Ein- und Ausschalter  
Lautstärkeregler

Bandbreiteregler  
Tonblende

# SABA

## Schaltschema für S 355 W

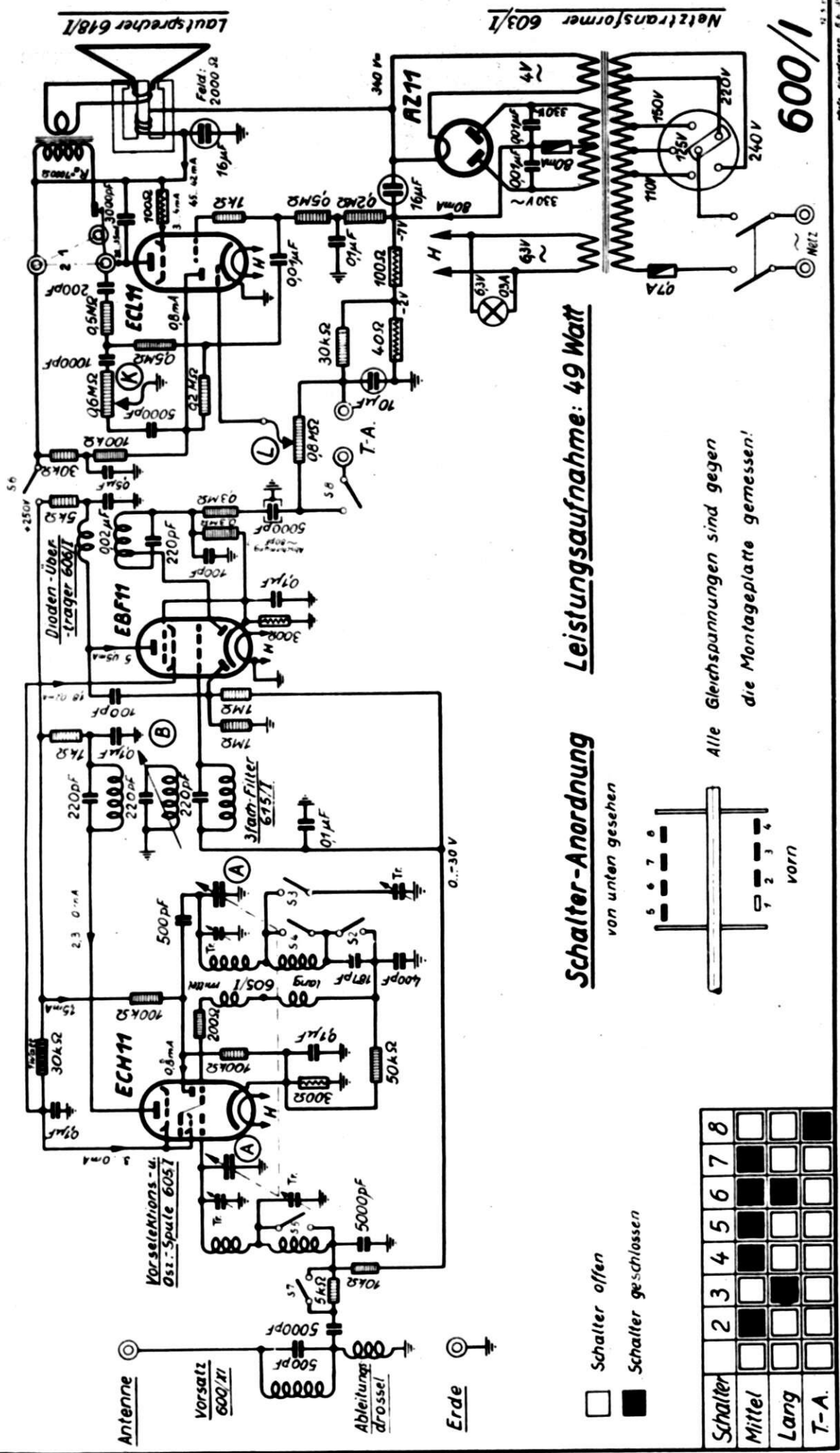

Leistungsaufnahme: 49 Watt

Schalter-Anordnung

von unten gesehen

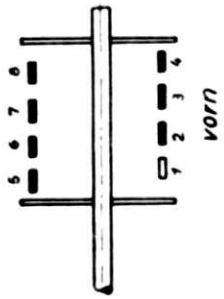

- Schalter offen
- Schalter geschlossen

Schalter	2	3	4	5	6	7	8
Mittel							
Lang							
T-A.							

Alle Gleichspannungen sind gegen die Montageplatte gemessen!

600/1

12.5.12



# Ersatzteilliste für S 355 W u. 356 GW



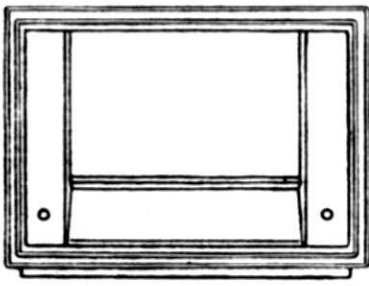
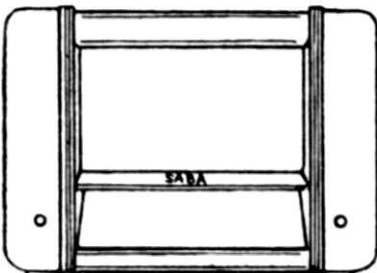
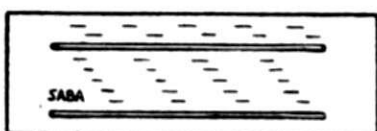
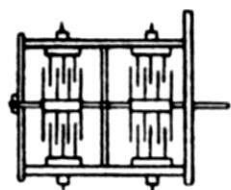
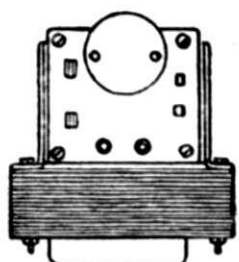
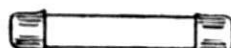
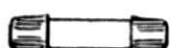

Blatt 1

355  
356

Benennung	Bestell-Nr.	Preis RM.	Gewicht netto gr.	Bemerkungen
 Holzgehäuse	600/1	26.—	3800	
 Preßgehäuse	600/2	22.—	3000	
 Skala	600/5	3.—	300	
 Drehkondensator	616/1	6.—	750	
 Netztransformator	603/1	8.—	2300	für S 355 W
  Sicherungen	563/75	— .15	1	0,7 A für S 355
	590/113	— .15	1	120 mA für S 356
	600/119	— .15	1	80 mA für S 355
	563/74	— .15	1	0,35 A für S 356

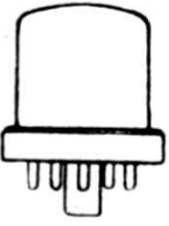
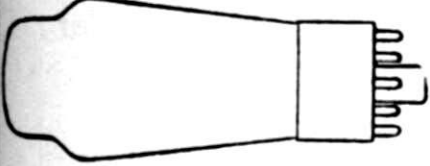
## Ersatzteilliste für S 355 W u. 356 GW

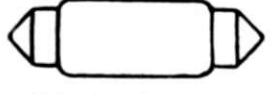
Blatt 2

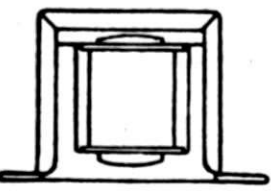
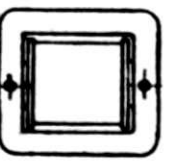

Benennung	Bestell-Nr.	Preis RM.	Gewicht netto gr.	Bemerkungen
 Metallröhre			50 50 50 50	ECH 11 für S 355 W EBF 11 für S 355 W UCH 11 für S 356 GW UBF 11
 Glasröhre			60 60 45 45	ECL 11 für S 355 W UCL 11 für S 356 GW AZ 11 für S 355 W UY 11 für S 356 GW
 Urdox	601/116	2.35	30	10 V 0,1 A U 1010/P für S 356 GW
 Skalenlampe	580/111	-.40	2	6,3 V 0,3 A für 355 W
	601/117 " "	-.40	2	18 V 0,1 A für S 356 GW
 Lautsprecher	618/I	18.--	2900	DW 41 Feld 2000 Ohm Anpassung 7000 Ohm für S 355 W
	618/III	20.—	2250	Permadyne 41 Anpassung 4500 Ohm für S 356 GW
  Drossel	622/I	2.80	330	Eingangsdrossel
	455/VII	2.80	360	Siebdrossel
	609/V	1.80	120	Heizdrossel

355  
356

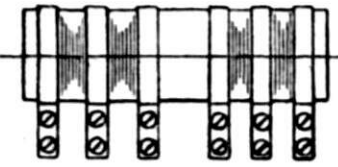
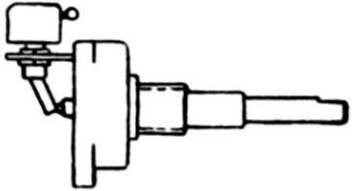
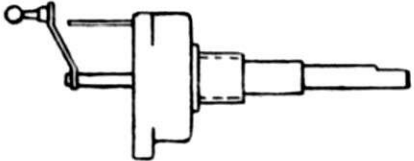
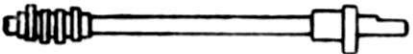
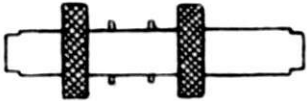

# Ersatzteilliste für S 355 W u. 356 GW

Blatt 3

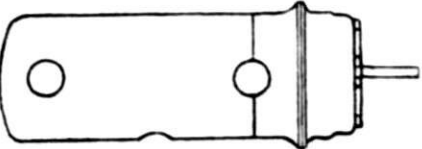
Benennung	Bestell-Nr.	Preis RM.	Gewicht netto gr.	Bemerkungen
 <p>Spannungsteiler</p>	609/XI	1.—	70	200 + 220 Ohm 125 + 75 Ohm für S 356 GW
 <p>Lautstärkereglер</p>	600/52	2.50	70	0,8 M Ohm
 <p>Potentiometer</p>	600/53	1.80	70	Tonblende 0,6 M Ohm
 <p>Nockenwelle</p>	600/XX	—.60	30	
 <p>Zwfr.-Sperre</p>	600/XII	1.—	35	
 <p>Vorsel. u. Oszillators-pule</p>	605/I	7.50	120	
 <p>Dreifach-Bandfilter</p>	615/I	6.—	200	

355  
356

## Ersatzteilliste für S 355 W u. 356 GW

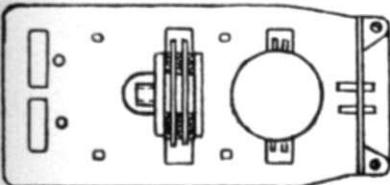
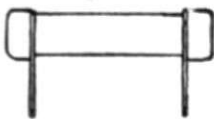
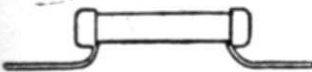
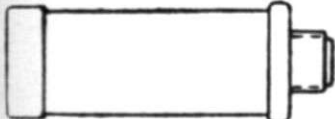
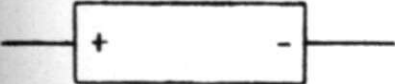

Blatt 4

Benennung	Bestell-Nr.	Preis RM.	Gewicht netto gr.	Bemerkungen
 Dioden-Übertrager	606/1	3.80	75	
 Drahtwiderstand	382/XXII	— .30	3	35 Ohm
	382/XXV	— .30	3	40 "
	382/III	— .30	3	50 "
	382/XV	— .30	3	100 "
	382/XXIII	— .30	3	110 "
	382/V	— .30	3	300 "
 Einbau-Widerstand	580/148	— .25	2	200 Ohm
	360/98	— .25	2	1 K "
	601/142	— .25	2	25 K " 1 W
	370/105	— .25	2	30 K " 1 W
	332/122	— .25	2	30 K "
	181/26	— .25	2	50 K "
	138/28	— .25	2	0,1 M "
	138/29	— .25	2	0,2 M "
	216/9	— .25	2	0,5 M "
	112/68	— .25	2	1 M "
 Elektrolyt-Kondensator	600/81	3.20	60	12 $\mu$ F
	601/81	4.—	60	28 $\mu$ F
 Elektrolyt-Kondensator	452/4	1.—	10	10 $\mu$ F
	452/7	1.—	18	25 $\mu$ F

**355**  
**356**

# Ersatzteilliste für S 355 W u. 356 GW

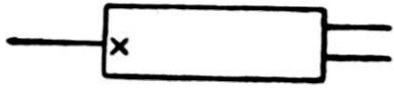
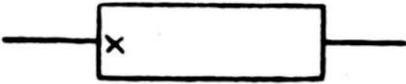
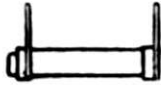
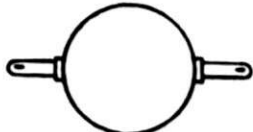
Blatt 5

Benennung	Bestell-Nr.	Preis RM.	Gewicht netto gr.	Bemerkungen
 Einbau-Kondensator	442/77	-.90	16	2 × 0,1 μF
	442/78	-.90	16	2 × 0,1 „
 Einbau-Kondensator	442/54	-.40	5	200 pF
	442/57	-.40	5	500 „
	442/58	-.40	6	1000 „
	442/53	-.40	6	3000 „
	442/33	-.40	6	5000 „
	442/62	-.40	6	5000 „
	442/63	-.40	7	0,01 μF
	453/36	-.40	8	0,01 „
	442/66	-.40	7	0,02 „
	442/73	-.90	10	0,2 „
	442/74	-.90	12	0,5 „
	442/75	-.90	12	0,5 „
442/61	1.20	16	1 „	
 Einbau-Kondensator	462/12	-.40	2	100 pF
 Einbau-Kondensator	472/33	-.60	5	187 pF
	472/35	-.60	5	220 „
	472/39	-.60	5	400 „
	472/37	-.60	5	500 „
 Netzschur mit Haube u. Gegenstück	603/XII und 603/34	1.40	150	

355  
356



## Ersatzteilliste für S 355 W u. 356 GW

Blatt 6

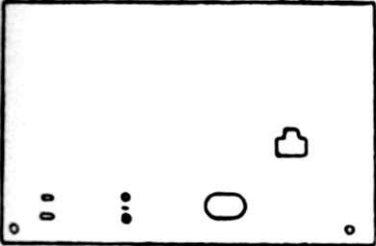
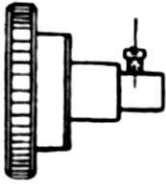
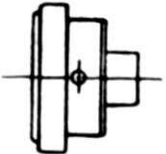
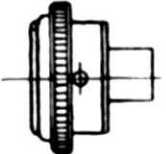
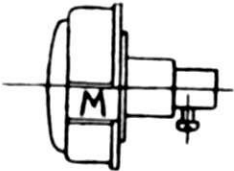
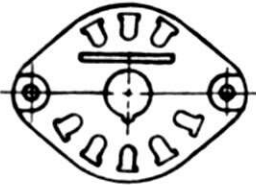
Benennung	Bestell-Nr.	Preis RM.	Gewicht netto gr.	Bemerkungen
 <p>Rückwand</p>	600/13 600/15 601/15	1.80 1.80 1.80	420 420 420	S 355 Holz S 355 Preßg. S 356 Preßg.
 <p>Drehknopf</p>	600/XXXa	—.40	20	für Stationswähler
	600/XXXII	—.40	20	für Holzgehäuse (vorn)
 <p>Drehknopf</p>	580/XXXV	—.40	20	für Preßgehäuse (vorn)
 <p>Drehknopf</p>	600/XXXIa	—.40	25	für Wellenschalter
 <p>Röhrensockel</p>	580/54	—.30	12	

**355**  
**356**